

## FT2 HALL EFFECT DETECTION DATA SHEET

**Economical**  
**PPS body**  
**1- 2% FSD or  $\pm 0.75\%$  reading\***  
**Sapphire bearings**  
**Hall effect sensor**  
**9 Flow ranges**  
**Pulse output**  
**15 Bar rating**  
**Viton seal as std.**  
**Choice of fittings**  
**0.1% Repeatability**  
**5 to 24 V dc**  
**125°C Max**

\*When used with Metra-smart instrument.

**Ideal for**

Opaque fluids  
 OEM use  
 Water treatment  
 Cooling equipment  
 Active flow alarms  
 Semiconductor plant  
 Engine test



FT2 Flowmeter various fitting options

This multi-range radial flow turbine meter uses a low inertia turbine supported on robust sapphire bearings in a chemically resistant housing. Nine flow ranges (0.05 to 160 litres per minute), a choice of "plug in" fittings and individual traceable calibration make this meter one of the most flexible available. It is inherently non-metallic so is ideal for use with aggressive chemicals. For OEM applications the fittings can be tailored to suit the installation and speed production. Custom leads or connectors are also available for quantity orders.



TITAN ENTERPRISES LTD.

Coldharbour Business Park,  
 Sherborne,  
 Dorset,  
 DT9 4JW

Phone (44) 01935 812790.

Fax (44) 01935 812890

Web [www.flowmeters.co.uk](http://www.flowmeters.co.uk)

Sales@flowmeters.co.uk

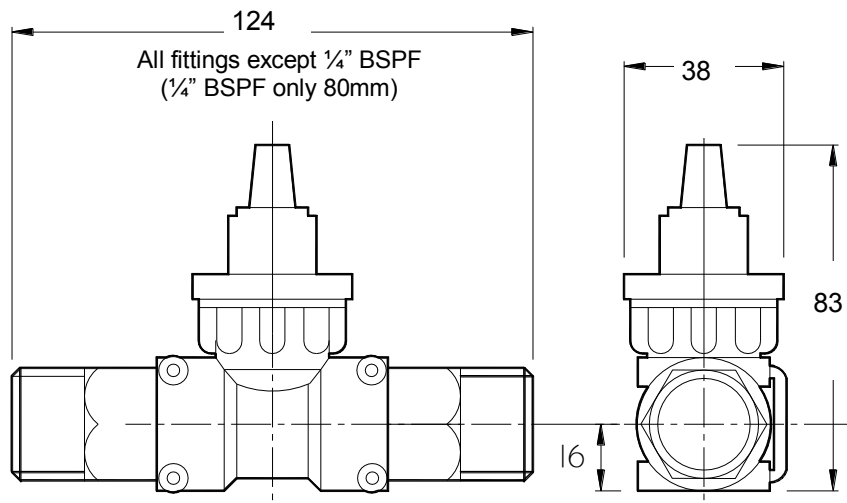

## Order Codes

Detector **22** Hall effect 5-24V dc

Type ↓

Conn-  
ection  
○ Rubber grommet  
P 4 Pin socket  
N IP67 gland

Flow  
range  
↓  
**100** etc see chart

'O' ring  
Mat'l  
↓  
V - Viton  
N - Nitrile  
E - EPDM  
S - Silicon

Fitting  
size  
↓  
25 - 1/4" BSP F  
50 - 1/2" BSP M  
75 - 3/4" BSP M  
**10** - 1" BSP M  
8H - 8mm hose  
0H - 13mm hose

Fitting  
mat'l  
↓  
B - Brass  
P - PVDF  
S - 316 St St  
P - PVC 60°C max

Special  
code  
↓  
OEM customer

e.g. **22 0-100-V- 10-B** is a standard flowmeter with a flow range of 4.0 to 100 L/Min, Viton seal and 1" BSP brass fittings with a standard 6 point traceable water calibration.

## Standard Materials of construction

Body and cap - PPS  
'O' Ring seal - Viton  
Bearings - Sapphire  
End fittings - PVDF,  
PVC,  
St St,  
Brass.

# Order code	Flow range L/Min	Linearity % FSD	Typical Freq. Hz.	Approx 'K' Factor
004	0.05 - 0.5	2.0	133	1600
016	0.12 - 1.6	1.5	205	7750
045	0.15 - 4.5	1.5	318	4250
065	0.25 - 6.5	1.0	260	2400
010	0.60 - 10	1.0	210	1250
030	2.50 - 30	1.5	275	550
060	5.00 - 60	1.5	275	275
<u>100</u>	6.00 - 100	2.0	275	165
160	10.00 - 160	1.5	320	120

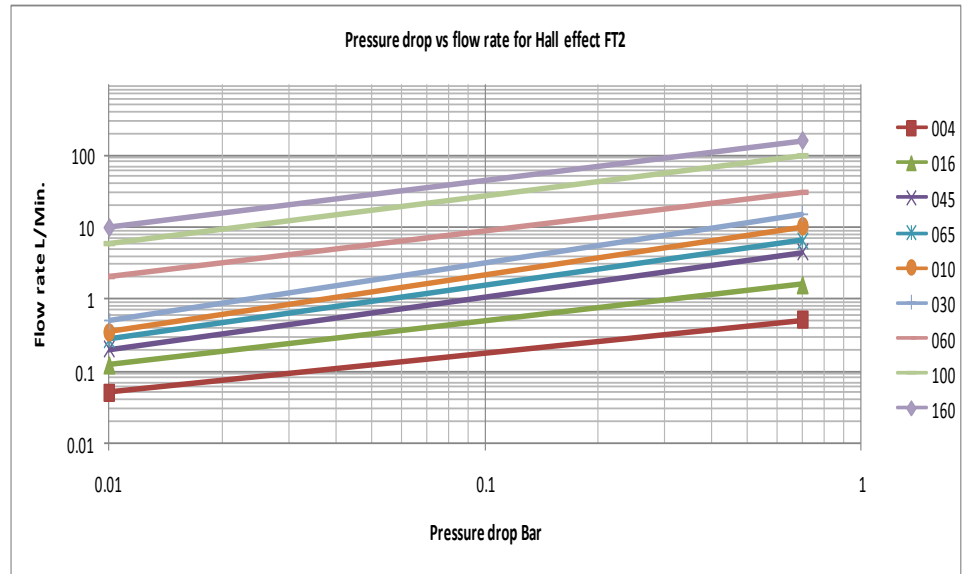

At the heart of the meter is a precision turbine that rotates freely on robust sapphire bearings. This rotation is detected when a turbine magnets pass the Hall effect sensor. The resulting output is a NPN pulse that is readily interfaced with most electronic display or recording devices. This combination of materials and technology ensures a long life product with reliable operation throughout. Because the flowmeter is so versatile with respect to flow range and fittings every combination of range and fitting is not available. The chart below shows the maximum standard flow rate/fitting we would recommend to attain our performance figures. Alternatives are possible but there would be degradation in the meters performance.

Fitting	Recommended Max flow L/Min.	PVC	PVDF	Brass	316 St St
8mm hose	4.5	*			
13mm hose	10	*			
1/4" BSP female	4.5		*	*	*
1/2" BSP male	30		*	*	*
3/4" BSP male	100	*	*	*	*
1" BSP male	160	*		*	*