

Instruction sheet

Metra-smart & Metra-view instruction sheet

Operation	page 2
Key functions	page 2
Mounting systems	page 2
Input types	page 3
Outputs	page 3
Programming	page 4 & 5
Terminal layout	page 6



1.3 Overview

The METRA series instruments are specifically designed for computing, displaying and transmitting totals and flowrate from flowmeters with pulse or frequency outputs.

The instrument will display Flow Rate, Resettable Total and an Accumulated Total in engineering units as programmed by the user. Simple flow chart programming with scrolling English prompts guide you through the programming routine greatly reducing the need to refer to the instruction manual. All user program data is retained if the battery is removed.

Special Features

Standard : 10 point Linearisation, PIN Protection, NPN/PNP selectable autoranging pulse outputs (*scaled or un-scaled*), Low frequency cut-off, Battery conservation mode.

Optional : 4~20mA output, High / Low flow alarms with adjustable deadbands, Dual inputs.

Environments

The UNIT is weatherproof to IP66 (Nema 4X) standards, UV resistant glass reinforced nylon with stainless screws & viton O-ring seals. The instrument suits harsh indoor and outdoor environments & conforms to EMC directive 89/336/EEC Electro Magnetic Compatibility.

Conforming standards include:

- EN 61326 (immunity in industrial locations)
- EN 62326 (emissions in industrial locations)
- EN 60529 (degrees of protection [IP])

Installation

Specifically engineered to be directly mounted on a variety of flowmeters, wall or surface mounted, pipe or panel mounted. Various mounting kits are available. The instrument can be self powered or may be powered by an external dc supply or two wire loop powered.



Full LCD display test feature illuminates all display segments and script text displays for 5 seconds when entering the program mode.



RATE display has flashing SEC, MIN, HR or day followed by up to 5 digits of rate programmable for up to 3 "floating" decimal places.

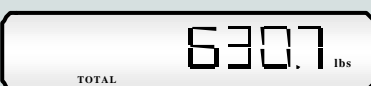

The 8 digit **TOTAL** is push button or remote resettable and can be programmed for up to 3 decimal places.



The 8 digit **ACCUMULATIVE TOTAL** display can be programmed for up to 3 decimal places. Reset is only possible when in the programme mode which can be PIN protected for security.

OPERATION

2.1 Accumulative Total

Accumulative total can be reset at L2 in the program mode see page 4. The accumulative total can be displayed momentarily or continuously through use of the front panel ACCUM TOTAL key.

Momentary display : Accumulative total is displayed only whilst the key is held pressed.

Latching display : To have the accum. total display latch when key is pressed simply press & hold the ACCUM TOTAL key for 10 seconds, the display will then latch each time the key is pressed. Holding the accumulative total key again for 10 seconds will revert this key function back to a momentary action.

2.2 Resettable Total (also see connections for remote reset feature)

The display toggles between Rate & Total when the RATE-TOTAL key is pressed. Pressing the RESET key whilst displaying total will cause the total to reset to zero.

2.3 Rate display

When rate is displayed the leading three alpha characters on the left of the display "flash" the time base for rate eg. rate /SEC, rate /MIN, rate /HR, or rate /DAY. Decimal points float to provide good resolution & rangeability.

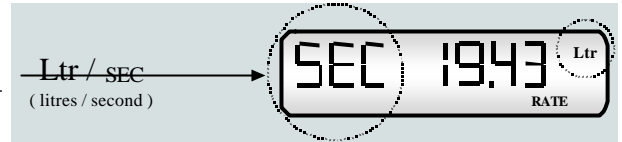

The minimum input frequency for rate display is 0.3hz reducing to 0.1hz If the low frequency cut-off is set to 0.1Hz (see below).

2.4 Low frequency cut-off

The low frequency cut-off is most commonly set to 0.0Hz (disabled) other than to:

- 1) To display rate for input frequencies below 0.3hz, for example setting the cut-off at 0.1Hz the rate will continue to display for input frequencies as low as 0.1Hz (one pulse every 10 seconds), such conditions often apply to flowmeters with low resolution pulse outputs (low frequency) or flowmeters with a high operational turndown (maximum to minimum flow rate).
- 2) Inhibit the integration & registration of "apparent flow" which at times may be encountered on mobile installations where the movement of the vehicle or dead heading a pulsating pump may cause spurious flow signals which are not attributed to actual flow.
- 3) Inhibit the integration & registration of flow at input frequencies below what is considered the minimum accurate flow rate of the primary flow element (flowmeter).

Caution: If the low frequency cut-off is set to any value other than 0.0Hz then the integration of rate and total will cease at frequencies on or below the set value (HEUNITZ).

2.5 Inhibit total (see wiring schematic page 18)

With the remote "inhibit total" switch closed the UNIT with display flow rate but at the same time will inhibit the resettable & accumulative totalising functions.

KEY	FUNCTION IN OPERATING MODE	FUNCTION IN PROGRAM MODE
	Displays Accumulative Total when pressed. (refer clause 2.1 for options)	No function
	Toggles between Rate & Total displays.	No function
	Resets the Total display to zero only when Total is being displayed.	No function
	1) Pressing the Prog. & Rate/Total keys for 5 seconds enters you into the program mode. 2) Displays model & software revision No.	1) Each press steps you through each level of the program chart. 2) Holding for 3 seconds fast tracks to the end of the program from any program level.
	No function	Selects the digit to be set, the selected digit will be "flashing" indicating that it can be incremented.
	No function	Increments the selected digit each time that it is pressed.

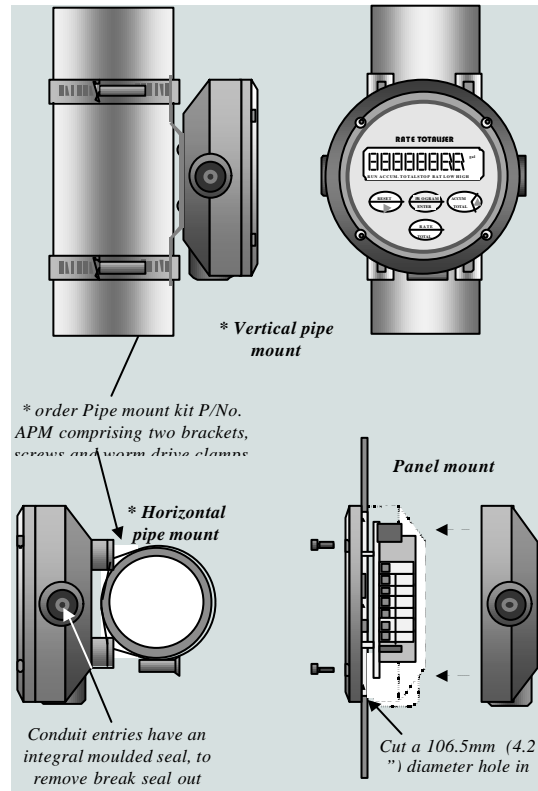
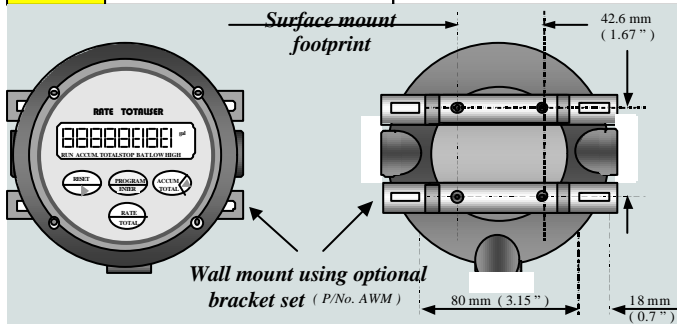

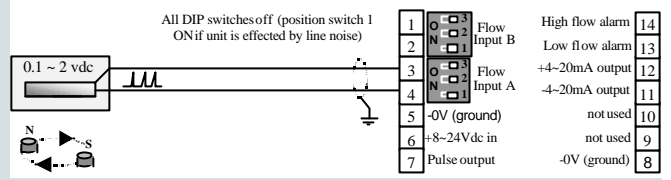
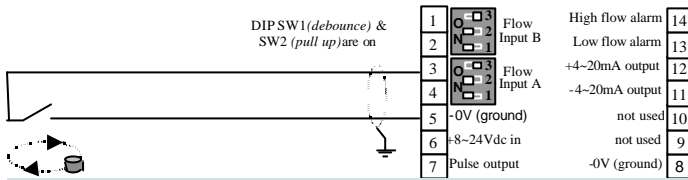

Coil (turbine type)

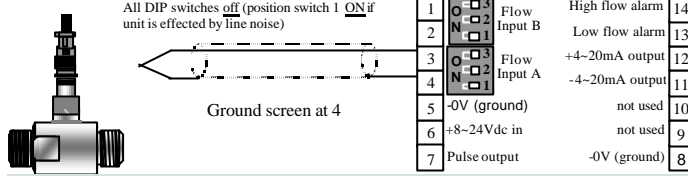

Hall Effect (open collector)

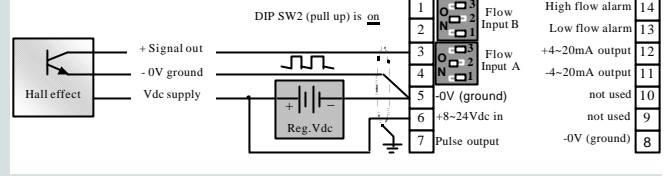

NAMUR (inductive proximity switch)

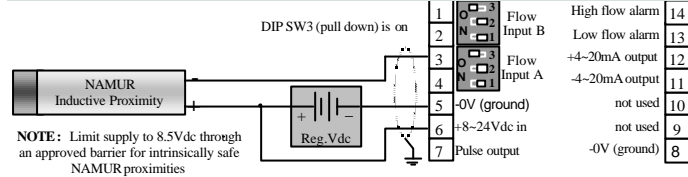

Current modulated pulse (4mA mark & 20mA space)

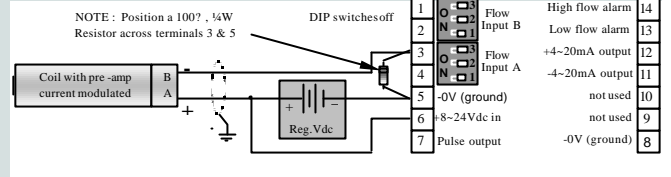

External DC powering

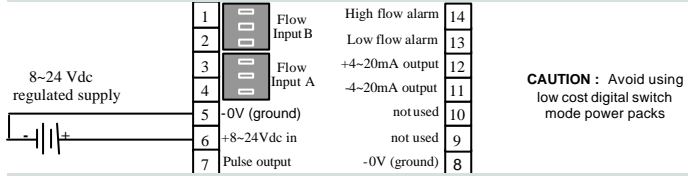

Powering via 4~20mA loop

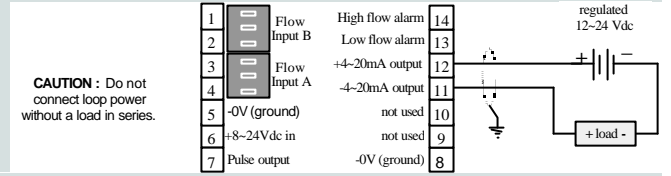

Note 1: The 4~20mA loop power supply is to be an isolated & regulated dc supply. The integral battery serves as a back up power source to enable the unit to continue to totalise if the loop power is lost.
Note 2: A separate dc power supply must be used to power active (powered) flow sensors, scaled pulse output and/or alarm outputs.

Wiring requirements

Use multi-core screened twisted pair instrument cable (0.25 – 0.5mm²) for electrical connection between the unit and any remote flowmeter or receiving instrument. The screen needs to be earthed to the signal ground of the receiving instrument, this is to protect the transmitted signal from mutual inductive interference. Do not earth the screen at both ends of the cable as this may induce interference.

Instrument cabling should not be run in a common conduit or parallel with power and high inductive load carrying cables, power surges & power line frequencies may induce erroneous noise transients onto the signal. Run instrument cables in a separate conduit or with other instrument cables.

Pulse & Alarm Outputs (Metra-smart only)

Current Sinking outputs (NPN)

Current sinking derives its name from the fact that it "sinks current from a load". When activated the current flows from the load into the appropriate output (7, 13 & 14).

Driving a logic input The output voltage pulse is typically the internal voltage of the load. The load would normally have an internal pull up resistor on its input as shown.

Driving a coil The NPN style of output is to be used when driving a coil. The coil load is obtained by dividing the coil voltage by coil impedance (), is expressed in amps & is not to exceed 0.1A. The coil voltage is connected across & must match the UNIT supply voltage & the output (7, 13 & 14).

Current Sourcing outputs (PNP)

Current sourcing gets its name from the fact that it "sources current to a load". When activated the current flows from the output (7, 13 & 14) into the load. When wired as below the output voltage pulse is the supply voltage of the load. The load would normally have an internal pull down resistor on its input as shown.

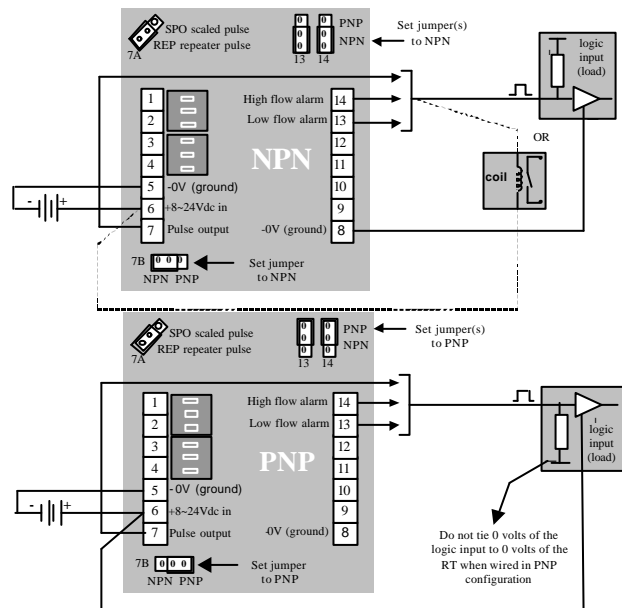

PROGRAM PARAMETERS (models METRA-VIEW & SMART)

4.1 PIN No. Program Protection

Any user defined PIN number other than 0000 will engage the program protection feature, failure to input the correct PIN number will deny the ability to change any of the program parameters but will allow the user to step through and view the existing program parameters. Only one PIN number may be set but this can be changed at any time after gaining access through PIN entry. A second back up PIN number is installed at the factory should the programmed PIN be lost or forgotten.

4.2 Resetting Accumulated Total

Resetting the accumulated total can only be done at level 2 (L2) in the program mode.

4.3 Engineering Units (refer clause 1.4)

Select from available Engineering units to right of the display. No eng units denote NIL set.

4.4 K-factor (scale factor)

Enter K-factor starting with the most significant number, up to 7 whole numbers & 3 decimal numbers can be entered. Trailing decimal numbers move into view as digits to the right are progressively selected, any significant digits which may move from view remain functional.

4.5 Rate conversion factor

A rate conversion feature is available at level 6 in the program chart.

4.6 Rate dampening

Dampening is available to smooth out fluctuating flow input signals in order to provide a stable rate display & analog output. Most input signal are reasonably stable and need only a low setting value of 40 to 70 (see response graph on page 6).

4.7 Low frequency cut-off This feature is explained in clause 2.4 (page 2).

4.8 Pulse Outputs (Instrument must be externally powered)

The pulse output is link selectable as a scaleable pulse or non-scaled repeater pulse & NPN (current sinking) or PNP (current sourcing) style pulse capable of switching up to 1 amp. Pulse scaling, when selected, is set as the number of litres / gallons etc. per output pulse. Eg. 0.1 litres/pulse, 10 litres/pulse, 100 gallons/pulse. Range is 0.1 - 9999.9 Eng.unit/pulse. The pulse width (pulse duration 1:1) automatically adjusts to the output frequency defaulting to a maximum pulse width of 300 milliseconds at frequencies below 1.66hz. To calculate pulse width at higher frequencies use: $1000 \div (\text{hz} \times 2) = \text{pulse width in milliseconds}$.

4.9 Non Linearity Correction (NLC) - Linearisation

Linearisation enables the instrument to correct for known inaccuracies in a flowmeter thereby improving the overall accuracy and in many cases increasing the effective flow range (turndown) of the flowmeter. Refer to program level L12, for setting NLC points. NLC can be used without external power however, battery life is reduced according to usage.

Note: The unit defaults out of the program mode if no programming entries are made after 4 minutes.

4.10 Presetting battery power levels

When the instrument is operated under battery power only a special "Power Mode" program option will appear at level 13 within the programming routine. A choice of three battery power modes enable maximisation of the battery life according to operational requirements:

Ultra Power Save: Usually selected if reading the meter infrequently. The display scrolls "PRESS ANY KEY", when a key is pressed display wakes for 4 minutes then returns to sleep mode* greatly extending battery life.

Standby: Display becomes active whenever a key is pressed or product flows through the flowmeter. Display returns to sleep mode* after 4 minutes of no flow input or key actions, prompt then returns to "PRESS ANY KEY".

Continuous: Display is active at all times resulting in reduced battery life. Display reverts from Rate to Total after 4 minutes to reduce battery draw.

* In all modes flow is always continually totalised.

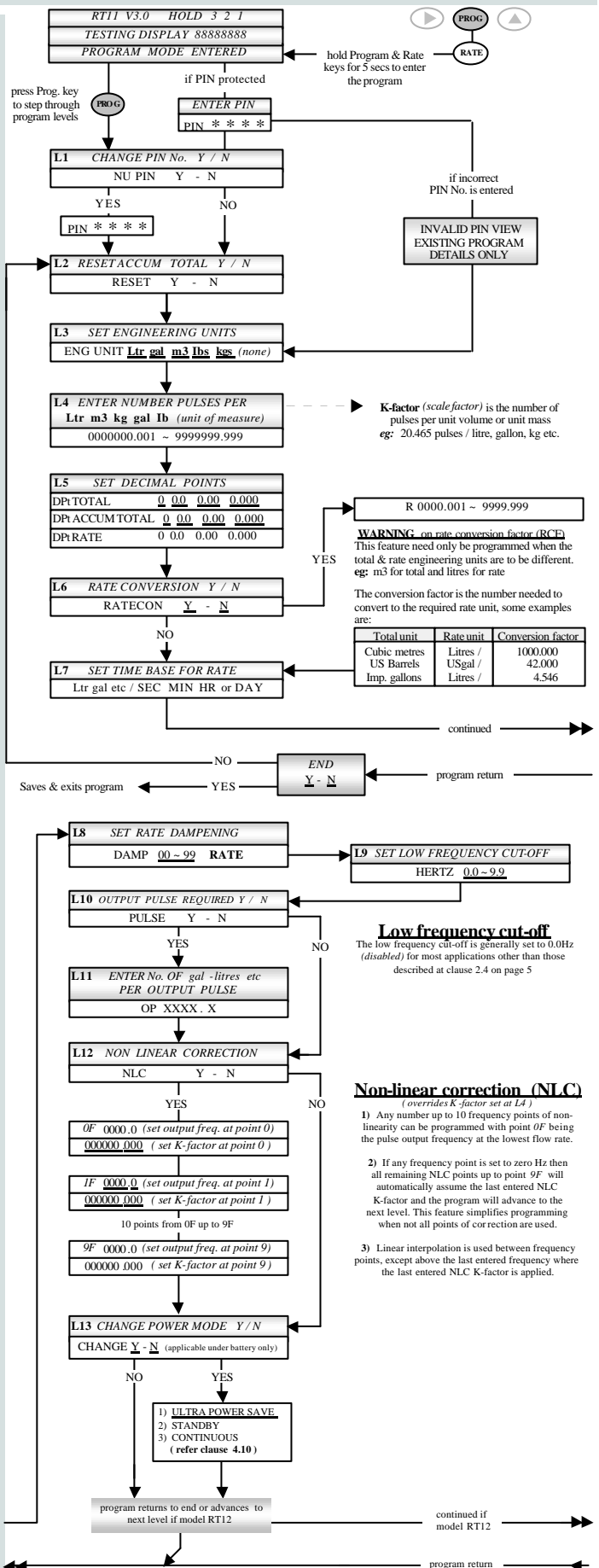

Pencil your program details here

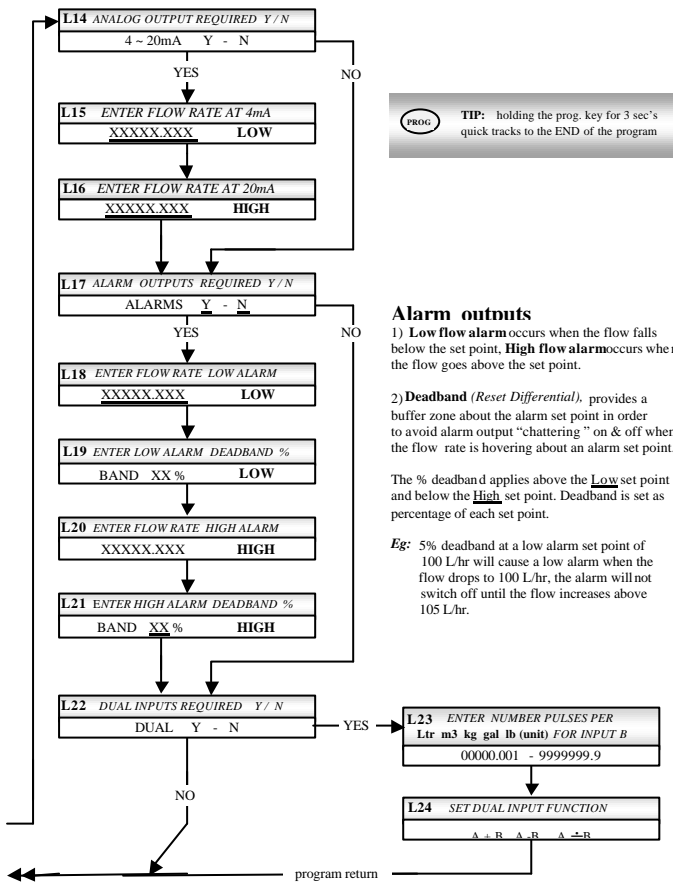

L1	User selected PIN	
L3	Engineering units	
L4	K-factor (scale)	K =
L5	Decimal for reset	<input type="checkbox"/> 0 <input type="checkbox"/> 0.0 <input type="checkbox"/> 0.00 <input type="checkbox"/> 0.000
	Decimal for Accum.	<input type="checkbox"/> 0 <input type="checkbox"/> 0.0 <input type="checkbox"/> 0.00 <input type="checkbox"/> 0.000
	Decimal for Rate	<input type="checkbox"/> 0 <input type="checkbox"/> 0.0 <input type="checkbox"/> 0.00 <input type="checkbox"/> 0.000
I 6	Rate conversion	<input type="checkbox"/> yes <input type="checkbox"/> RCF=
I 7	Time base for Rate	Units / <input type="checkbox"/> Sec <input type="checkbox"/> Min <input type="checkbox"/> Hr
I 8	Rate dampening	
I 9	Low frequency cut-	Hertz =
I 10	Pulse output	<input type="checkbox"/> yes <input type="checkbox"/> L11 pulse value =
I 11	Non linear correction	<input type="checkbox"/> yes <input type="checkbox"/> no
	- frequency 0	0F K-factor =
	- frequency 1	1F K-factor =
	- frequency 2	2F K-factor =
	- frequency 3	3F K-factor =
	- frequency 4	4F K-factor =
	- frequency 5	5F K-factor =
	- frequency 6	6F K-factor =
	- frequency 7	7F K-factor =
	- frequency 8	8F K-factor =
	- frequency 9	9F K-factor =
	- frequency 0	9F K-factor =
L13	Power mode	<input type="checkbox"/> Ultra save <input type="checkbox"/> Standby <input type="checkbox"/>
I 14	Analog output	<input type="checkbox"/> yes <input type="checkbox"/> no
I 15	- zero set point	4mA @
I 16	- span set point	20mA @
I 17	Alarm outputs	<input type="checkbox"/> yes <input type="checkbox"/> no
I 18	- low set point	@
I 19	- low deadband	percentag %
I 20	- high set point	@
I 21	- high deadband	percentag %
I 22	Dual flow inputs	<input type="checkbox"/> yes <input type="checkbox"/> no
I 23	- K factor for B	K -
I 24	- dual input	<input type="checkbox"/> A+B <input type="checkbox"/> A-B <input type="checkbox"/>

ADDITIONAL PROGRAM PARAMETERS (model METRA-SMART)

5.1 Analog Output (Metra-smart only)

The loop powered 4~20mA output can be spanned anywhere within the flow meter range. Testing the current loop is available during programming when 4mA will output at programming level L15 and 20mA will output at level L16.

5.2 Flow Alarms

Two flow alarm FET (transistor) outputs may be programmed for Low & High flow alarms.

5.3 Flow Alarm Deadband

Alarms are NPN/PNP link selectable. An adjustable deadband (reset differential) provides a trip buffer zone about the set point in order to overcome alarm "chattering" when the flow rate is fluctuating close to the alarm set point.

Deadband is entered as % of each set point value.

5.4 Dual Flow Inputs

When externally powered the METRA-SMART accepts inputs from two flowmeters (input A & input B), a separate scaling factor is entered for the second flow input, the instrument is then programmed for one of the dual input functions of A+B, A-B or A÷B (ratio).

A+B Both inputs are added and displayed as one for Rate & Totals.

A-B Input B is subtracted from input A & the difference is displayed for both Rate & Totals.

A÷B Totalises A & B separately & Rate is a function of A÷B to give instantaneous ratio.

Note : - When using A & B inputs the functions of Scaled Pulse output, Alarm set points and the Analog output are relevant to resultant computation between A & B.
 - The analog output of function A÷B can be used as an input for ratio control.

1	Flow input B	High flow alarm	14
2	Flow input B	Low flow alarm	13
3	Flow input A	+4 - 20 mA output	12
4	Flow input A	-4 - 20 mA output	11
5	-0V (ground)	Not used	10
6	+8 - 24 Vdc in	Not used	9
7	Pulse output	-0V (ground)	8

TERMINAL DESIGNATION

Terminal layout - links & remote switch inputs

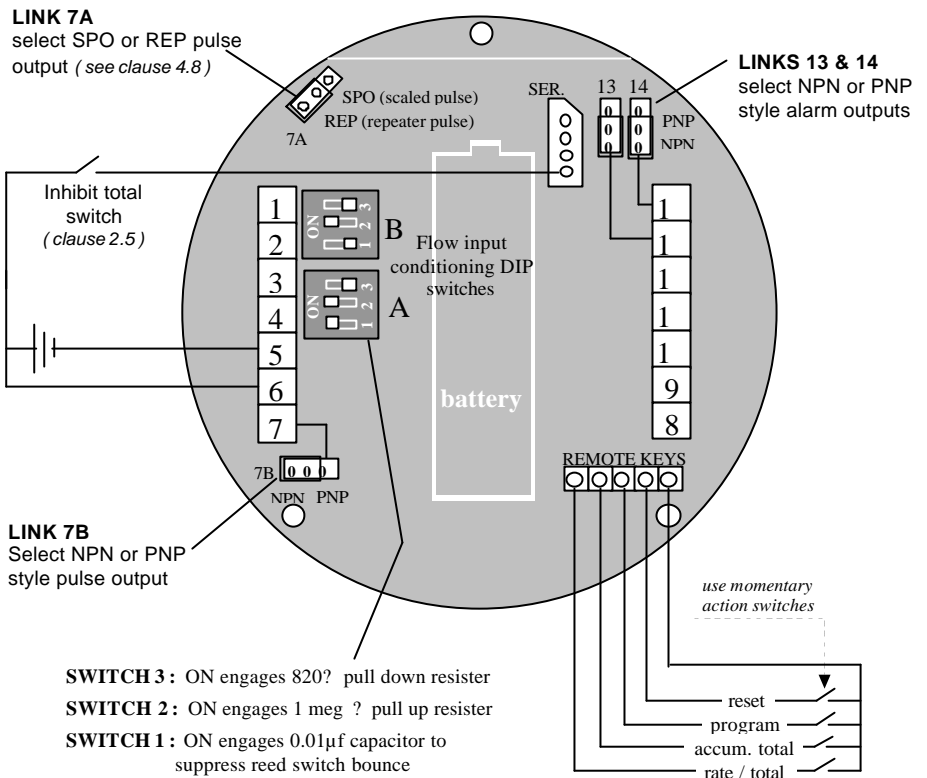

Rate dampening :

Rate dampening value verses time to reach new reading (for an instantaneous change in actual flow rate)

